

# BF SERIES - Balanced Signal Converters with Common Mode Injection Port

This line of transformers provides a highly balanced transverse signal source in the 0.1 to 100MHz frequency range. Balance in this case refers to the equality of voltages of either leg with respect to ground. The BF series of transformers have a built in common mode signal injection circuit and provide an ideal means to measure the susceptibility of balanced or UTP systems to noise and interference.

The BF series of transformers are supplied with standard BNC (F) connectors for easy connection to signal or data source, common mode injection network, communications analyzer or bit error rate tester.

Socket terminals are provided for the balanced output connections.



North Hills BF Series Balanced Signal Converter.

## Features:

- Converts an unbalanced coaxial input signal to a highly-balanced output signal
- Balanced output impedances of 100, 120, 135 or 150 ohms

## Benefits:

- Provides an easy way to measure susceptibility of balanced systems to noise and interference
- Covers frequency range from 10kHz to 100MHz
- Custom impedances also available

## Typical Measurement Setup:

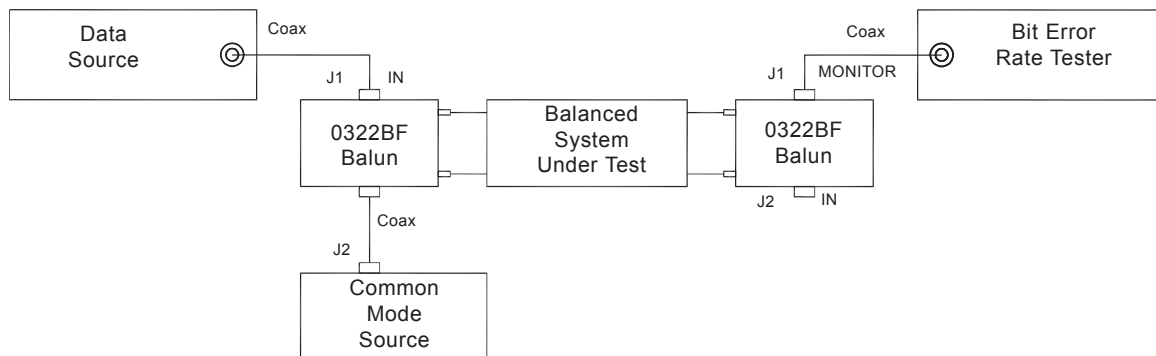



# BF Series - Balanced Signal Converters with Common Mode Injection Port

Provides a highly balanced source of transverse voltage in the 0.1 to 100MHz frequency range.

## Simplified Schematic:

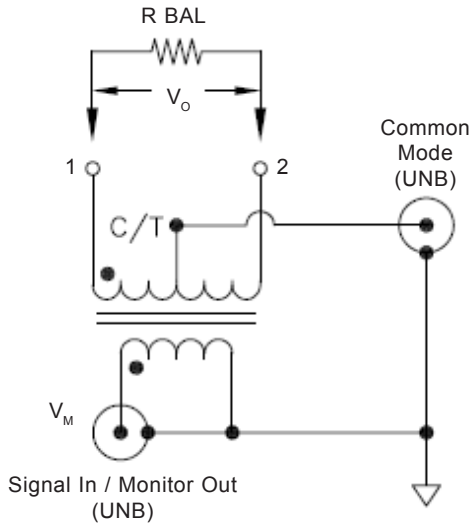

## Case Style:

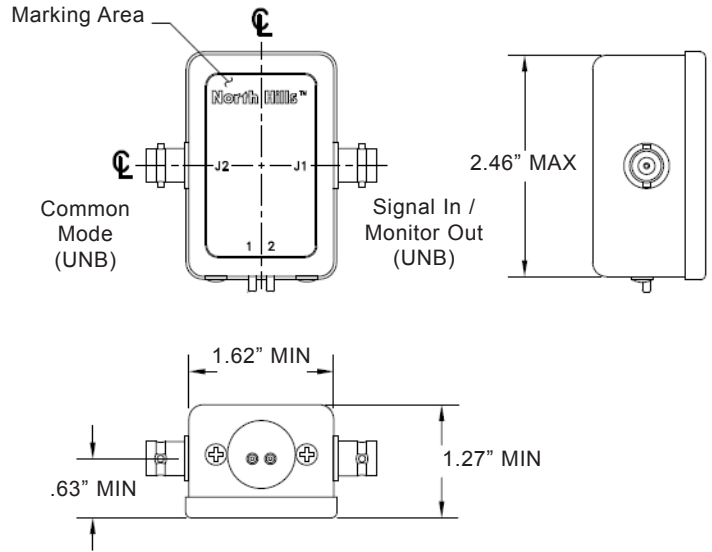

## Ordering Information:

Parameter	MODEL #							
	0320BF	0322BF	0323BF	0409BF	0410BF	0411BF	0412BF	0413BF
Impedance (UNB : BAL) $\Omega$	50 : 100	50 : 100	50 : 110	50 : 135	50 : 150	50 : 135	50 : 150	50 : 120
Frequency Range (MHz), 3 dB	.01 - 30	.1 - 100	.01 - 30	.01 - 30	.01 - 30	.1 - 100	.1 - 100	.1 - 100
Return Loss Min., dB	20	20	20	20	20	20	20	20
Longitudinal Balance: Up to 30 MHz	-60 dB	-60 dB	-60 dB	-60 dB	-60 dB	-60 dB	-60 dB	-60 dB
30-100 MHz	-	-50 dB	-	-	-	-50 dB	-50 dB	-50 dB
Correction Factor	-3.6dB	-3.6dB	-3.6dB	-4.9dB	-5.3dB	-4.9dB	-5.3dB	-3.6dB
Operating Temperature ( $^{\circ}\text{C}$ )	0 to 50	0 to 50	0 to 50	0 to 50	0 to 50	0 to 50	0 to 50	0 to 50
Storage Temperature ( $^{\circ}\text{C}$ )	-20 to 70	-20 to 70	-20 to 70	-20 to 70	-20 to 70	-20 to 70	-20 to 70	-20 to 70
Connections: UUT Input Monitor	Terminal BNC (F)	Terminal BNC (F)	Terminal BNC (F)	Terminal BNC (F)	Terminal BNC (F)	Terminal BNC (F)	Terminal BNC (F)	Terminal BNC (F)

Note 1. No dc isolation between unbalanced and balanced ports.

Note 2. Correction factor accounts for turns ratio and power loss of the impedance matching transformer in the balun. Correction factor should be subtracted from actual longitudinal balance reading.

*Specifications subject to change without notice.*