

## C.I.S.P.R. 17/IEC 1981 Transformers Application Note

The C.I.S.P.R. 17/IEC 1981 (“CISPR 17”) standard describes the method of insertion loss measurement of passive radio-frequency suppression filters, i.e., how useful the filter is in reducing noise. These filters can consist of either inductors, capacitors, resistors, or any combination thereof, either in a distributed or lumped arrangement. 50Ω test set-ups are used in most applications of insertion loss measurement as a matter of convenience, but they do not accurately represent the impedance conditions in a real-world set-up. CISPR 17 provides alternative measurement methods, one of which is CISPR 17’s “Approximate Method for Power Line Filters,” described in Paragraph 4.2.2.2 of the standard. This provides a test setup of a 0.1Ω source impedance and a 100Ω load impedance (see Figures 1 and 3), as well as the reverse configuration, i.e., a 100Ω source impedance and a 0.1Ω load impedance (see Figures 2 and 4), all setups utilizing wideband transformers. CISPR 17 refers to this as a “0.1/100Ω (and Reverse) Measuring System.”

For balanced filters, North Hills’ Model NH16434 converts the unbalanced 50Ω generator impedance to a 0.1Ω balanced source impedance. In order to measure the filter output, a precision 100Ω balun is required. Since we are interested in measuring high values of attenuation, we have to ensure that the network analyzer measures the transverse signal rather than any common mode signal that may be generated at the input. North Hills’ Model 51100RBAL, a 50Ω:100Ω receive balun with a 10kHz to 30MHz bandwidth, is optimized for receiving the filter’s signal and transmitting it to the network analyzer. Together the NH16434 and 51100RBAL provide very high common mode rejection, ideal for completing this test circuit (see Figure 1). For the “reverse” circuit (see Figure 2), Model 51100TBAL, a 50Ω:100Ω balun optimized for transmission, and Model 51050RBAL, a 50Ω:50Ω balun optimized for receiving, both with bandwidths of 10kHz to 30MHz, also provide extraordinary common mode rejection, vital to making accurate measurements of transverse signals through the filter.

For unbalanced filters, North Hills’ Model NH16435 provides a 0.1Ω unbalanced source impedance. For the 100Ω output impedance, the network analyzer may be directly connected to the filter output with a 50Ω resistor in series (refer to Figure 3). For the 0.1Ω output impedance, i.e., the “reverse” unbalanced circuit, a precision 0.1Ω resistor is shunted across the 0.1Ω filter input, and the 100Ω filter input is connected to the network analyzer through a series 50Ω resistor (refer to Figure 4).

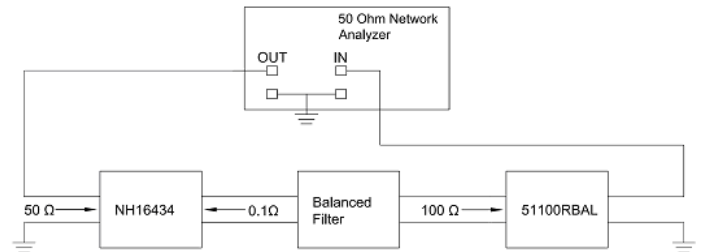

Figure 1. CISPR 17 Balanced 0.1Ω/100Ω Test Setup

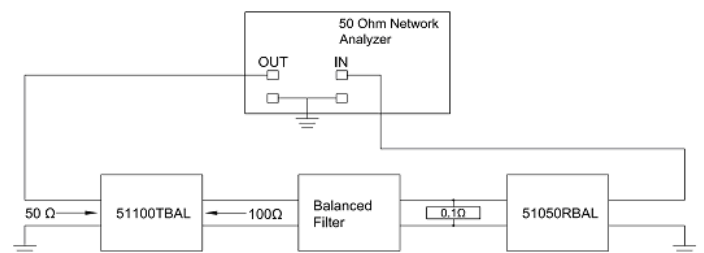

Figure 2. CISPR 17 Balanced 100Ω/0.1Ω Test Setup

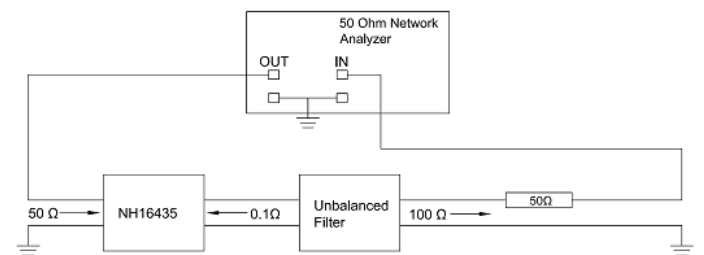

Figure 3. CISPR 17 Unbalanced 0.1Ω/100Ω Test Setup

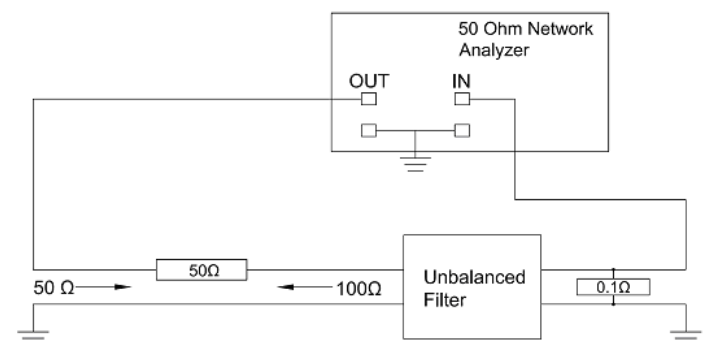

Figure 4. CISPR 17 Unbalanced 100Ω/0.1Ω Test Setup