

CMI/LBB Series - Two-Port Balance Test

Calibration Procedure

CMI/LBB Series - Two-Port Balance Test, Calibration Procedure

Longitudinal Conversion Transfer Loss (LCTL)

1. On the Network Analyzer, set the frequency range and select the Thru (B/R or S21) measurement. Adjust Reference Position to the top of the display if necessary.
2. Connect Network Analyzer Output to Input of Common Mode Injectors (CMI), Input to Mon of Longitudinal Balance Bridge (LBB). Insert/place the Calibration termination (supplied with CMI) to the balanced outputs (terminals) of the LBB and CMI. The input of the LBB should be terminated as shown.
3. Perform a Thru Calibration. Set Reference Level and Marker Offset to 30dB (see procedure for setting offsets). Remove the Calibration termination. You are now ready to test.

NOTE¹:

The above procedure has calibrated out the correction factor. The Network Analyzer can now be read directly as the LCTL value.

NOTE²:

For best performance, CMI unit should be purchased in pairs with LBB bridges. If LBB and CMI are purchased separately please contact customer service at 1-516-682-7740 for two-port Re-calibration procedure.

THRU MEASUREMENT (B/R)

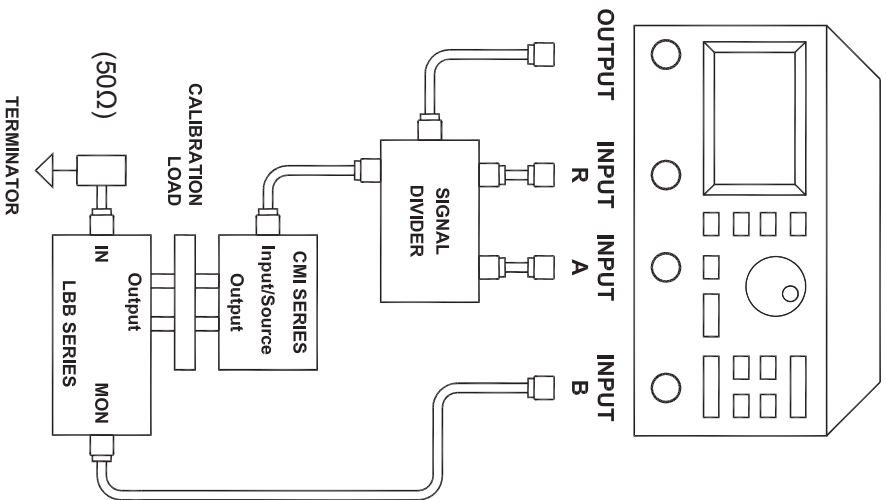

THRU MEASUREMENT (S21 / S12)

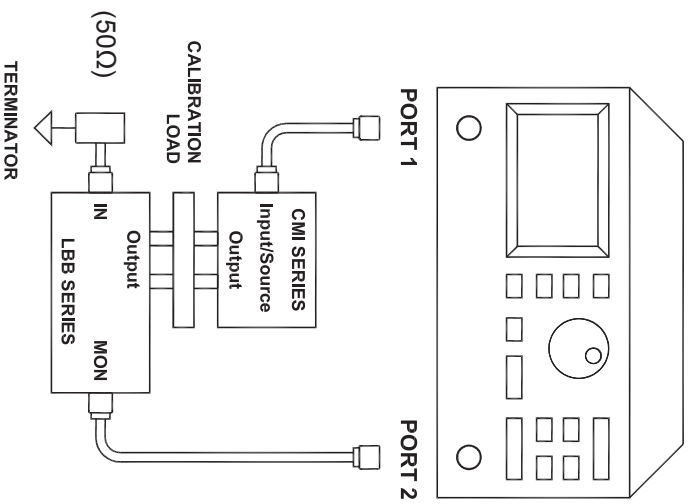

	PORT 1	PORT 2
S21	CMI, IN	LBB, MON
S12	LBB, MON	CMI, IN

Procedure for setting 30dB offset (or any other offset) on the HP3577A and HP8753C Network Analyzers:

HP3577A:

1. Press SCALE button.
 2. Press REF LEVEL button on the screen.
 3. Enter a value of 30dB.
-
1. Press the MKR button.
 2. Press MARKER OFFSET button on the screen.
 3. Enter a value of 30dB.
 4. Press MKR OFFSET ON button on the screen.

HP8753C:

1. Press SCALE REF button.
 2. Press REFERENCE VALUE button on the screen.
 3. Enter 30dB.
-
1. Press MKR button.
 2. Press Δ MODE MENU button on the screen.
 3. Press FIXED MKR POSITION on the screen.
 4. Press FIXED MKR VALUE on the screen.
 5. Enter 30dB. Press RETURN on the screen.
 6. Press Δ REF = Δ FIXED MKR on the screen.
 7. Press MKR button.

These examples are valid for HP3577A and HP8753C Network Analyzers only. Please consult the manuals of your Network Analyzers on setting up offsets (i.e., Offsetting Scale, Reference Level, Marker).



• 6851 JERICHO TURNPIKE • SYOSSET, NY 11791 •
• 1-516-682-7700 • FAX 1-516-682-7704 •
WWW.NORTHHILLS-SP.COM