

## Testing VDSL Remote (Customer) End Service Splitters

VDSL requires service-splitters at the network end as well as the remote customer end to separate the low-frequency telephone (POTS) and high-frequency data signals.

This Application Note outlines electrical tests of the Remote Customer End Splitter as covered in Annex E (pages 135-145) of ANSI Standard T1.424.2004.

The Remote End Service Splitter is shown in Fig.1. It consists of a pair of high-pass and low-pass filters in parallel with pass-band impedances and frequency ranges as shown.

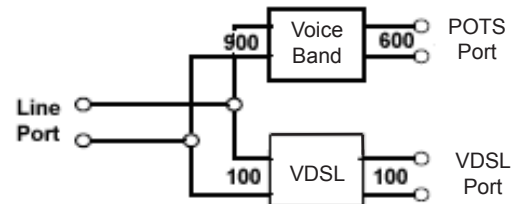

Fig. 1. Remote End Service Splitter

The following is a list of test circuits and associated tables and test devices to facilitate the prescribed measurements:

Test	ANSI Std. T1.424.2004 Requirement	Test Diagram	North Hills Device Key
<b>Line to POTS 0.2-4kHz, 25kHz - 12MHz</b>			
Insertion Loss <sup>1</sup>	Figure E.5 -- Table E.1	Figure 2	T1 = NH16186 & T2 = NH16185 or T1 = NH16189 & T2 = NH16188 ZHP= NH16274, MLP1=NH16410
Insertion Loss Ripple	Figure E.5 -- Table E.2		
Line Intermodulation Distortion	Figure E.5 -- Table E.4	Figure 2	T1= NH16186 T2= NH16185 ZHP= NH16274
Group Delay	Figure E.5 -- Table E.5		
<b>Line to VDSL 25kHz - 12MHz</b>			
Insertion Loss	Figure E.8 -- Table E.8	Figure 3	T3= NH16187 ZTR= NH16273
Insertion Loss Ripple	Figure E.8 -- Table E.9		
<b>Return Loss 25kHz - 12MHz</b>			
Return Loss	Figure E.9 -- Table E.10	Figure 4	RLB = 51100RLB ZTR = NH16273 ZTV = NH16409
<b>POTS Longitudinal Balance 0.2 - 3kHz</b>			
One Port Balance	Figure E.7 -- Table E.7	Figure 5	LBB1 = NH16392, ZTR = NH16272
Two Port Balance	Figure E.7 -- Table E.6	Figure 6	LBB1 = NH16392, CMI1 = NH16393

Note 1: Please refer to section on transmission in Application Note 160.

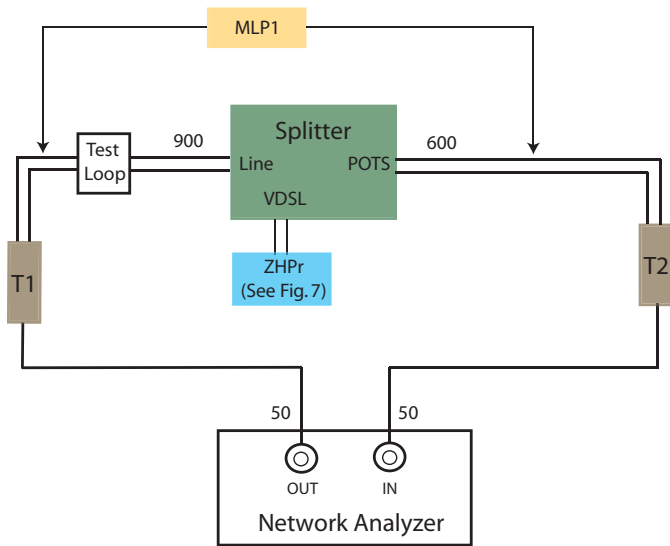

Fig. 2. Line to POTS Insertion Loss  
0.2 - 4kHz, 25kHz - 12MHz

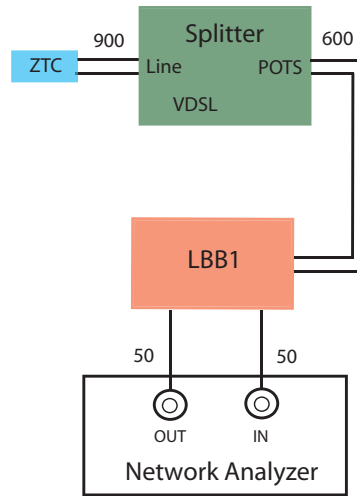

Fig. 5. One-Port POTS Longitudinal Balance  
0.2 - 3kHz

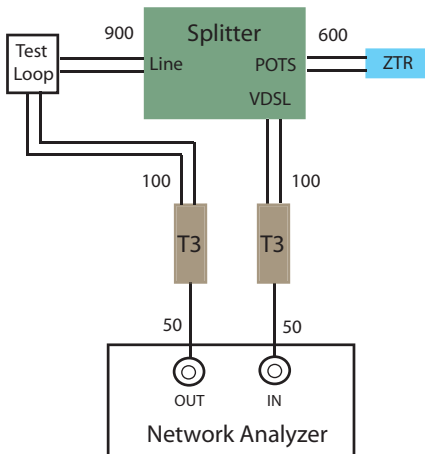

Fig. 3. Line to VDSL Insertion Loss  
25kHz - 12MHz

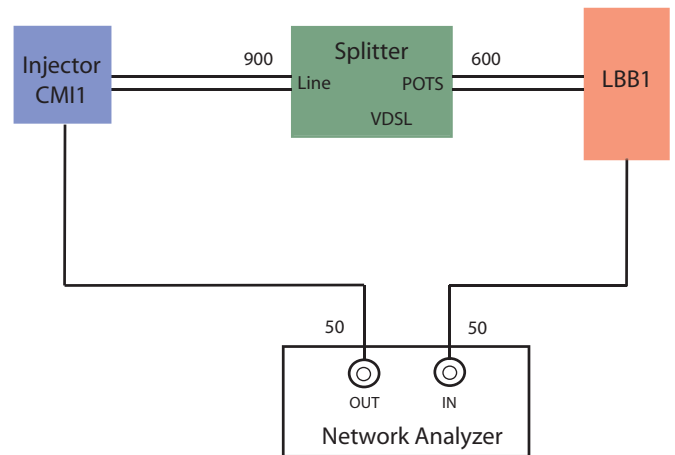

Fig. 6. Two-Port POTS Longitudinal Balance  
0.2 - 3kHz

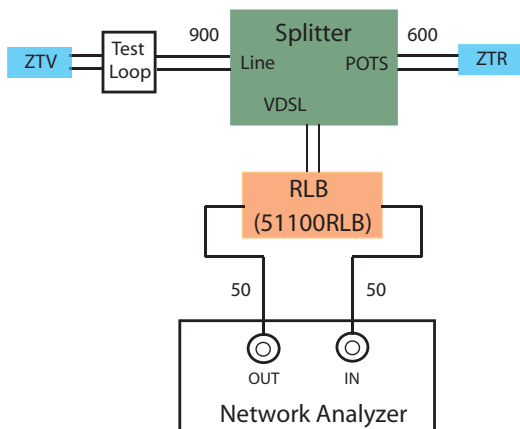

Fig. 4. VDSL Return Loss  
25kHz - 12MHz

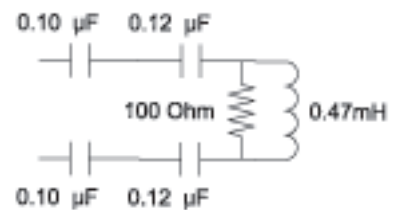

Fig. 7. ZHPr VDSL Port Termination Schematic

NORTH HILLS TEST DEVICE MODEL#	TEST DIAGRAM & DESIGNATION	DESCRIPTION & FREQUENCY RANGE
<b>Balun Transformers</b>		
NH16185	T2 in Figure 2	50:600--Voice Band (200Hz-25MHz)
NH16186	T1 in Figure 2	50:900--Voice Band (200Hz-25MHz)
NH16187	T3 in Figure 3	50:100--VDSL (25kHz-30MHz)
NH16188	T2 in Figure 2	50:600--VDSL (25kHz-30MHz)
NH16189	T1 in Figure 2	50:900--VDSL (25kHz-30MHz)
<b>Return Loss Bridges</b>		
51100RLB	RLB in Figure 4	0.01-30MHz
<b>Longitudinal Balance Bridges</b>		
NH16392	LBB1 in Figures 5 & 6	50:600, 0.2-3kHz
<b>Common Mode Injector Networks</b>		
NH16393	CMI1 in Figure 6	Common Mode Injector
<b>Termination Networks</b>		
NH16274	ZHPr in Figures 2 & 7	VDSL Port Termination
NH16273	ZTR in Figures 3 & 4	600 ohm Terminator
NH16272	ZTC in Figures 5	900 ohm Terminator
NH16409	ZTV in Figure 4	100 ohm Terminator
NH16410	MLP1 in Figure 2	900/600 ohm Min. Loss Pad

**Application Notes:**

- 156. Measurement of Longitudinal Balance
- 157. Return Loss Bridges
- 160. Two-Port Balanced Network Measurements