

## Testing VDSL Network End Service Splitters

VDSL requires service-splitters at the network end as well as remote customer end to separate the low-frequency telephone (POTS) and high-frequency data signals.

This Application Note outlines electrical tests of the Network End Splitter as covered in Annex F (pages 146-155) of ANSI Standard T1.424.2004.

The Network End Service Splitter is shown in Fig.1. It consists of a pair of high-pass and low-pass filters in parallel with pass-band impedances and frequency ranges as shown.

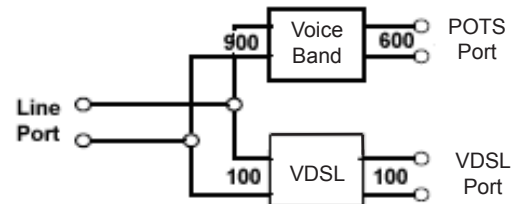

Fig. 1. Network End Service Splitter

The following is a list of test circuits and associated tables and test devices to facilitate the prescribed measurements:

Test	ANSI Std. T1.424.2004 Requirement	Test Diagram	North Hills Device Key
<b>Line to POTS 0.2-4kHz, 25kHz - 12MHz</b>			
Insertion Loss <sup>1</sup>	Figure F.5 -- Table F.1	Figure 2	T1 = NH16186 & T2 = NH16185 or T1 = NH16189 & T2 = NH16188 ZHPc= NH16408, MLP1=NH16410
Insertion Loss Ripple	Figure F.5 -- Table F.2		
Line Intermodulation Distortion	Figure F.5 -- Table F.4		
Group Delay	Figure F.5 -- Table F.5		
<b>Line to VDSL 25kHz - 12MHz</b>			
Insertion Loss	Figure F.9 -- Table F.8	Figure 3	T3= NH16187 ZTC= NH16272
Insertion Loss Ripple	Figure F.9 -- Table F.9		
<b>Return Loss 25kHz - 12MHz</b>			
Return Loss	Figure F.10 -- Table F.10	Figure 4	RLB = 51100RLB ZTC = NH16272 ZTV = NH16409
<b>POTS Longitudinal Balance 0.2 - 3kHz</b>			
One Port Balance	Figure F.7 -- Table F.7	Figure 5	LBB2 = NH16403, ZTR = NH16273
Two Port Balance	Figure F.7 -- Table F.6	Figure 6	LBB2 = NH16403, CMI2 = NH16404

Note 1: Please refer to section on transmission in Application Note 160.

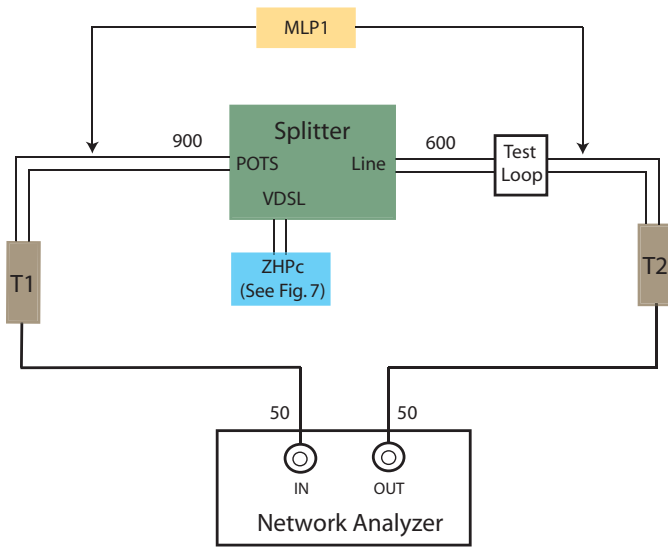

Fig. 2. Line to POTS Insertion Loss  
0.2 - 4kHz, 25kHz - 12MHz

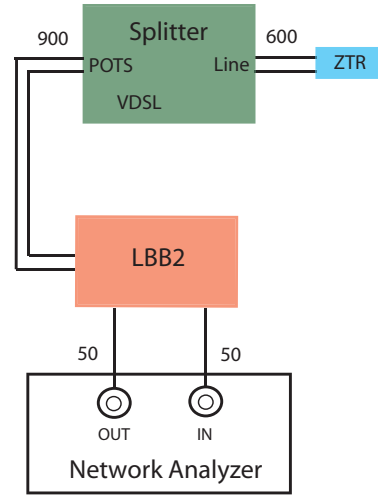

Fig. 5. One-Port POTS Longitudinal Balance  
0.2 - 3kHz

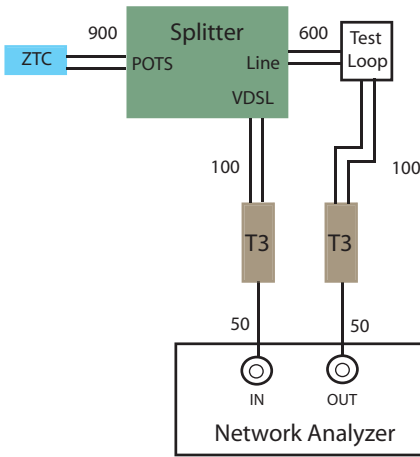

Fig. 3. Line to VDSL Port Insertion Loss  
25kHz - 12MHz

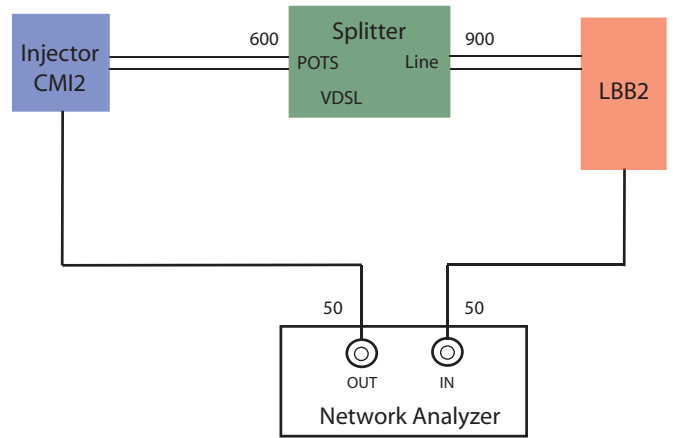

Fig. 6. Two-Port POTS Longitudinal Balance  
0.2 - 3kHz

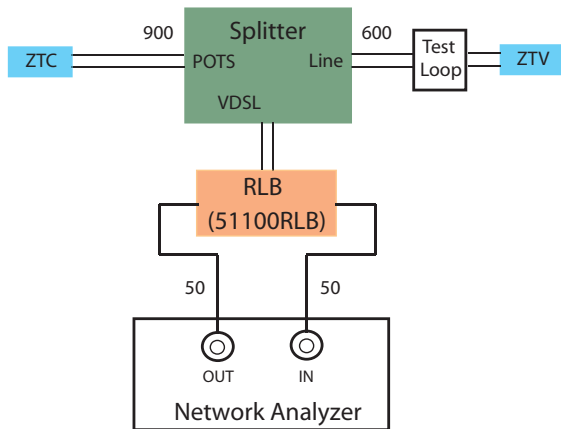

Fig. 4. VDSL Return Loss  
25kHz - 12MHz

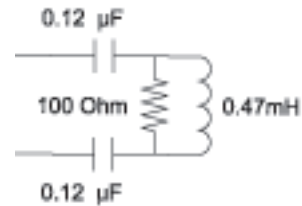

Fig. 7. ZHPc VDSL Port Termination Schematic

NORTH HILLS TEST DEVICE MODEL#	TEST DIAGRAM & DESIGNATION	DESCRIPTION & FREQUENCY RANGE
<b>Balun Transformers</b>		
NH16185	T2 in Figure 2	50:600--Voice Band (200Hz-25kHz)
NH16186	T1 in Figure 2	50:900--Voice Band (200Hz-25kHz)
NH16187	T3 in Figure 3	50:100--VDSL (25kHz-30MHz)
NH16188	T2 in Figure 2	50:600--VDSL (25kHz-30MHz)
NH16189	T1 in Figure 2	50:900--VDSL (25kHz-30MHz)
<b>Return Loss Bridges</b>		
51100RLB	RLB in Figure 4	0.01-30MHz
<b>Longitudinal Balance Bridges</b>		
NH16403	LBB2 in Figures 5 & 6	50:900, 0.2-3kHz
<b>Common Mode Injector Networks</b>		
NH16404	CMI2 in Figure 6	Common Mode Injector
<b>Termination Networks</b>		
NH16408	ZHPc in Figures 2 & 7	VDSL Port Termination
NH16273	ZTR in Figure 5	600 ohm Terminator
NH16272	ZTC in Figures 3 & 4	900 ohm Terminator
NH16409	ZTV in Figure 4	100 ohm Terminator
NH16410	MLP1 in Figure 2	900/600 ohm Min. Loss Pad

### Application Notes:

- 156. [Measurement of Longitudinal Balance](#)
- 157. [Return Loss Bridges](#)
- 160. [Two-Port Balanced Network Measurements](#)