

Two-Port Balanced Network Measurements

Fig. 1 shows a two-port balanced network, terminated on both sides, by characteristic impedances Z_1 and Z_2 . Most often $Z_1 = Z_2$.

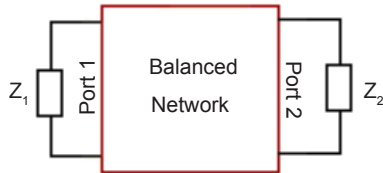

Fig. 1. Two-Port Balanced Network

Measurement of the important network characteristic, transmission, return loss, and balance to ground, are most conveniently performed using a network analyzer.

Transmission

The test setup for measuring the transmission characteristics of the network is shown in Fig. 2a. Since the network analyzer input and output are single ended, baluns are needed to perform the conversion to and from the two ports of the balanced network. To account for the losses in the two baluns, the setup of Fig 2b is used to calibrate the network analyzer when the baluns are similar, i.e. $Z_1 = Z_2$. The display is first normalized to read 0 dB.

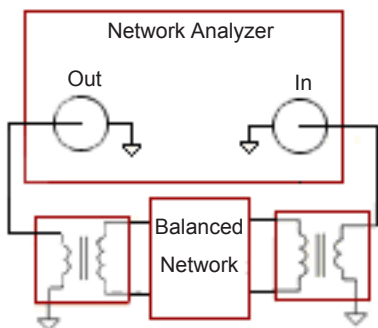

Fig. 2a. Two-Port Balanced Network

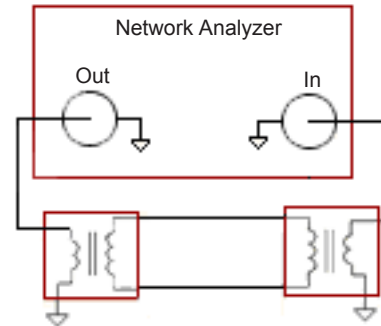

Fig. 2b. Normalizing Similar Baluns

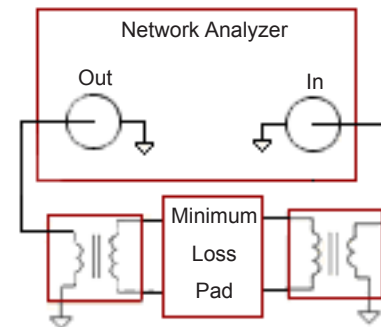

Fig. 2c. Normalizing Dissimilar Baluns

When the network is then inserted between the two baluns, as in Fig. 2a, the display will read the insertion loss and other characteristics of the network directly.

In the special situation where $Z_1 \neq Z_2$, a minimum loss pad is inserted to match the balanced impedances of the two baluns, as shown in Fig. 2c. After the network analyzer display is normalized at 0 dB, the trace is moved upwards by an amount equal to the known insertion loss of the pad.

The measured transmission characteristics of the network vs. frequency may include phase and group delay in addition to amplitude.

North Hills offers instrumentation quality wideband baluns to transform unbalanced impedances of 50 and 75 ohm to a wide array of balanced impedances. Models cover the frequency range from 20 Hz to 300 MHz.

Return Loss

Return Loss is defined and discussed in **Application Note 155**. It is, essentially, a measure of the variation of the input impedance from the characteristic or nominal impedance of the network.

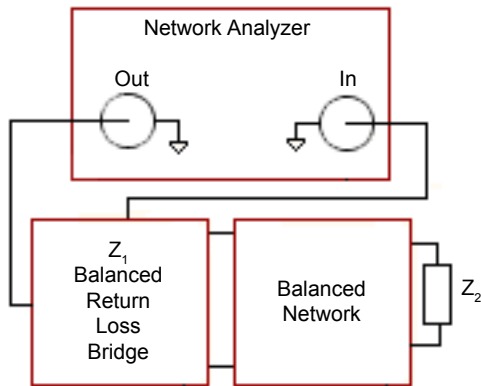

Fig. 3. Port 1 Return Loss Test

Fig. 3 shows the setup for measuring return loss, using a return loss bridge designed for the particular characteristic impedance.

North Hills RLB Series Return Loss Bridges are designed for balanced impedances between 100 and 150 ohm and frequency ranges from 10 kHz to 300 MHz.

Longitudinal Balance

Figure 4 shows the test circuit to measure balance to ground at Port 1 of the network. The Longitudinal Balance Bridge makes this measurement per ITU-T Recommendation O.9, which defines balance to ground as the ratio of the applied common mode voltage to the resulting line-to-line voltage across the network input port. More details on the topic of balanced to ground measurement are found in

Application Note 156.

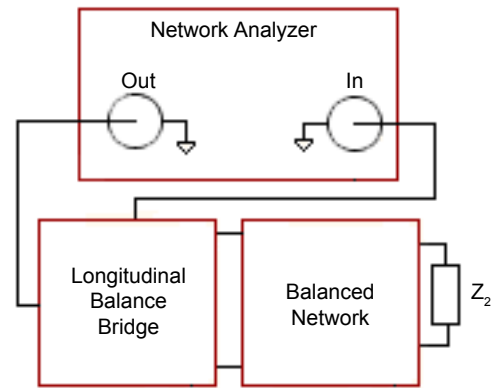

Fig. 4. Port 1 Longitudinal Balance Test

North Hills LBB Series Longitudinal Balance Bridges are designed for balance impedances between 100 and 150 ohm and frequency ranges from 10 kHz to 300 MHz.

Please don't hesitate to contact us to discuss your particular applications and needs.