

Balun Measurements

A Balun, as shown in Fig. 1, is a two-winding transformer designed to convert a single ended (i.e. one side grounded) signal to one balanced with respect to ground. The balanced winding may or may not be center-tapped. A center-tap would, ideally, be at a virtual ground and may be grounded, connected to a dc potential or left floating.

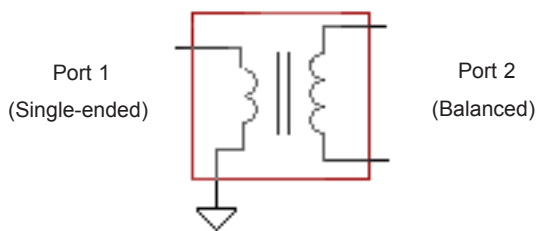

Fig. 1. Balun

The balun is thus a two-port device, Port 1 being single-ended, Port 2 balanced. The characteristics of each port may be described in terms of s parameters.

Balun Applications

Two major applications of baluns are:

1. Impedance matching for maximum power transfer.
2. Conversion of single-ended signals to a balanced configuration to facilitate efficient transmission of communication signals. Balanced systems reduce radiation and pick up, and alleviate the need for costly shielding.

For best performance baluns, must have low transmission or insertion loss and superior return loss.

To characterize a balun for impedance matching applications, one must measure its transmission and return loss.

For unbalanced to balanced signal conversion applications, balance with respect to ground is a key parameter.

Baluns are designed to operate between specific impedances. In the test circuits shown (Figs. 2-6), the Port 1 input impedance is assumed to be 50 ohm with Port 2 terminated in "R" ohms. This is a typical setup when using a 50 ohm network analyzer.

Transmission Tests

The test setup for measuring the transmission characteristics of the balun is shown in Fig.2. Because of the back-to-back connection, both s_{12} and s_{21} are measured at the same time.

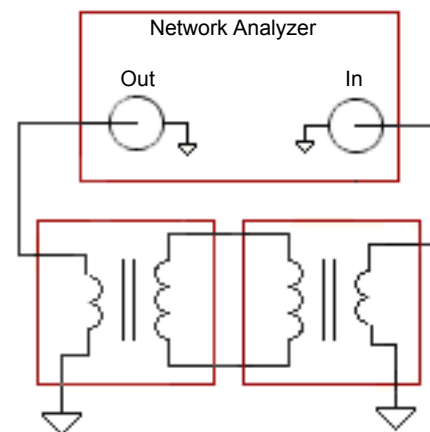

Fig. 2. Transmission Test

The measured characteristics may include amplitude, phase and group delay, which is the slope of the phase characteristic. The results must be divided by two to obtain figures per unit.

Return Loss Tests

Return loss is defined and discussed in Application

Note 155. It, is essentially, a measure of the variation of the input impedance from the characteristic or nominal impedance of the network.

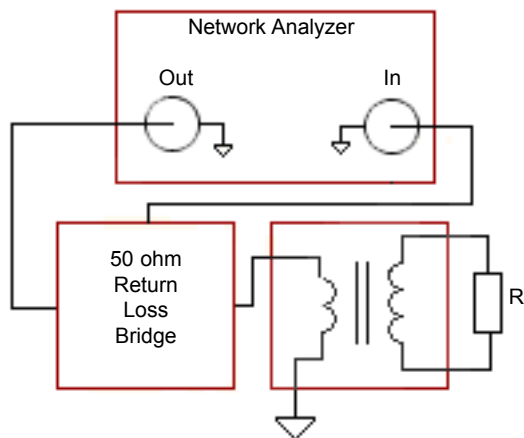

Fig. 3. Port 1 Return Loss Test

The measurements require return loss bridges designed for the specific characteristic impedances. Figures 3 and 4 show typical test configurations for measuring return loss using a network analyzer.

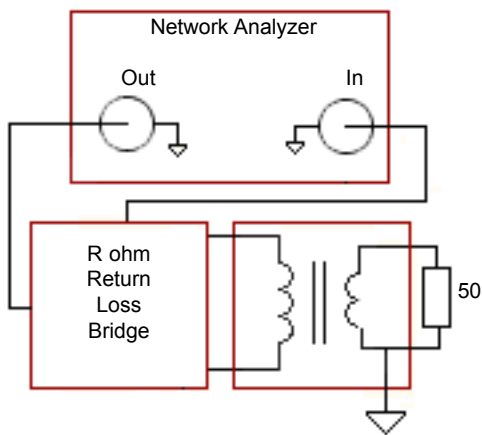

Fig. 4. Port 2 Return Loss Test

Longitudinal Balance Tests

In situations, where the degree of balance to ground is important, the balance of Port 2 can be measured using a Longitudinal Balance Bridge designed for the particular balanced impedance R. Figure 5 shows

one possible configuration of the test setup.

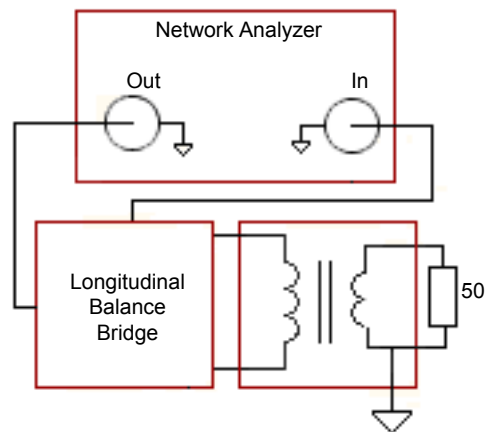

Fig. 5. Longitudinal Balance Test

Common Mode Rejection

Common mode rejection is also a characteristic which reflects the degree of balance of the balun transformer. Figure 6 depicts a typical setup and uses a common mode injection circuit to apply equal common mode voltage to the two legs of the balanced input.

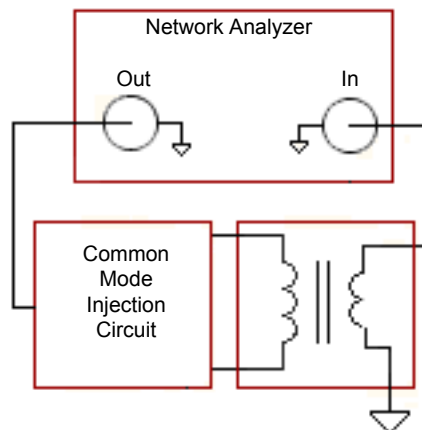

Fig. 6. Common Mode Rejection Test

Please don't hesitate to contact us to discuss your particular applications and needs.