

## Receiving Inspection of Data Bus Couplers

Checking MIL-STD-1553 data bus couplers at receiving inspection just got simpler. By using the DBT100A, a coupler can be functionally checked in a matter of seconds for continuity, opens, shorts, phasing and correct operation. It is ideally suited for large or small volume testing. All tests except resistance tests are go/no-go.

To test a coupler simply connect the unit to be tested as shown in Figure 1. With the terminators in place, test the coupler as if it were a multi stub bus network.

- 1.) Connect the Main Unit DBT100A to a stub of the unit under test.
- 2.) Depress buttons 1 - 5 and observe results.
  - Button 1** - go/no-go test. Checks for shorts between stub conductors and shield.
  - Button 2** - measures the resistance of the stub cable and transformer winding. It should be between 1 and 5 ohm depending on the coupler.
  - Button 3** - go/no-go test. Checks shorts between bus conductors and shield.
  - Button 4** - go/no-go test. Checks for shorts and opens on the bus and missing terminators.
  - Button 5** - go/no-go test. Checks for correct phasing (high low integrity).
- 3.) Repeat the tests for each stub of the unit under test.
- 4.) Reverse the positions of the known good unit and the unit under test to test the phasing of the other bus connector. See Figure 2.
- 5.) Connect the Remote Unit of the DBT100A to the known good coupler as shown in Figure 2 and test for phasing by repeating the button 5 test.

The coupler has now been fully tested for all functions.

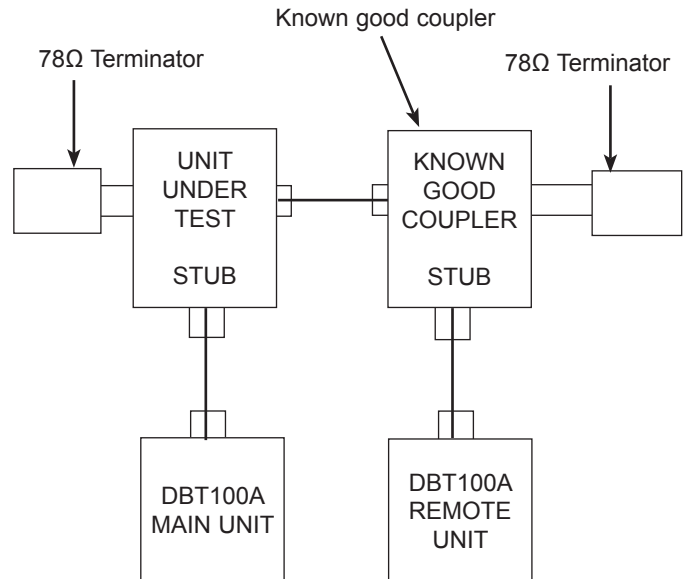

Figure 1. Test Setup.  
(Tests S1-S4, Buttons 1-4)

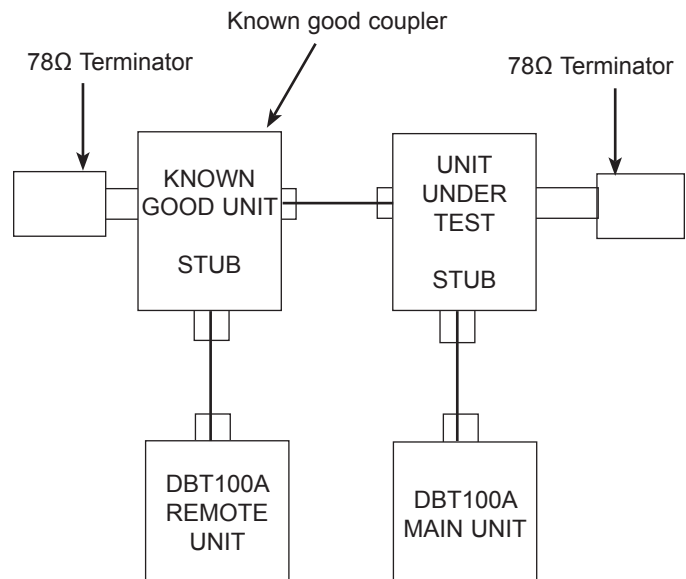

Figure 2. Second Test Setup for Phasing/Crossover.  
(Test S5, Button 5)